

© DEN HARTOG INDUSTRIES, INC.

Copyright. All information furnished within this document, electronic file or design correspondence is the property of Den Hartog industries, Inc. and shall not be used, disclosed to others or copied without the expressed written consent of Den Hartog Industries, Inc.

SPBM003-RT

A

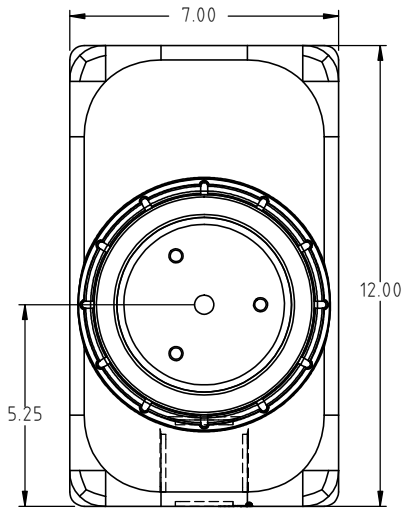

13696 5" VENTED LID

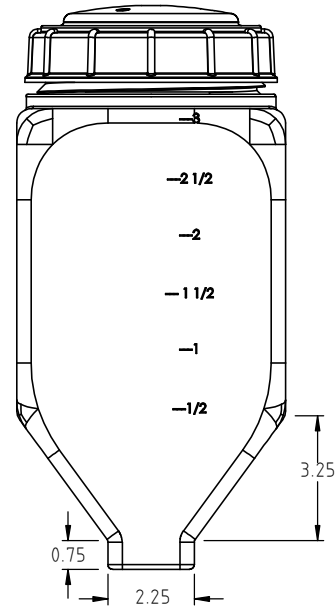
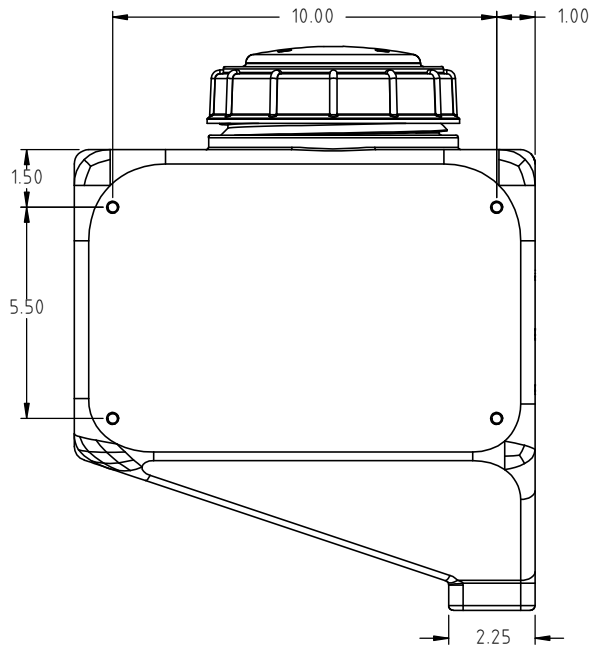
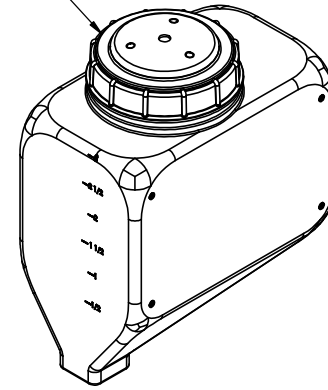

4 X 19382
5/16-18 UNC
BLIND NYLON
INSERT EACH SIDE

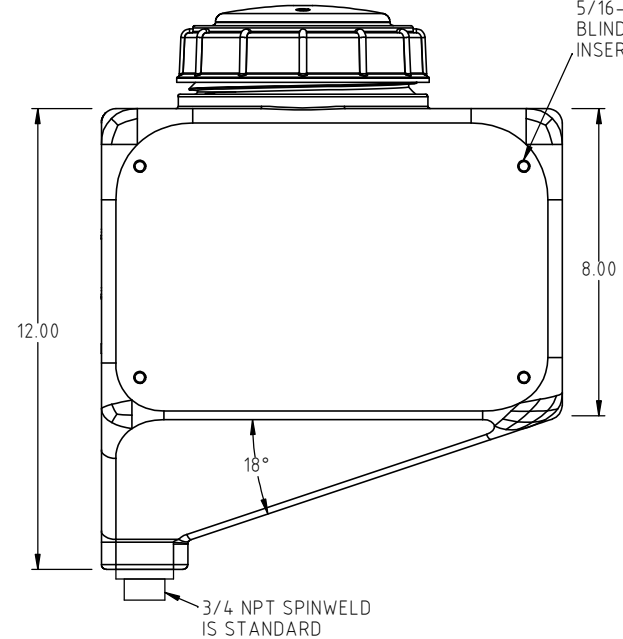

				DRAWN / DATE DHJ 1/6/05	MATERIAL 80001 PELLET
A	DESIGN UPDATED FOR BLOW MOLDING	REH 2/7/14	2798	APPRO. / DATE REH 1/7/05	
REV	DESCRIPTION	BY / DATE	CCN		
ALL DIMENSIONS ARE IN DECIMAL INCHES TOLERANCES UNLESS OTHERWISE SPECIFIED		THIRD ANGLE PROJECTION ANSI 14.5M		SHOT WEIGHT: 3 LBS.	NOTES: 1.) .150 NOM. WALL
POLYETHYLENE		METAL DECIMAL ± .125" FRACTION ± 1/4" ANGLE ± 1°		SHIPPING WEIGHT: 3.5 LBS.	
±1% @ 68°F				FINISH:	



Den Hartog
INDUSTRIES, INC.

Acra Roto-Mold Injection Molding Blow Molding Sowjoy

4010 HOSPERS DRIVE S. BOX 425, HOSPERS, IOWA 51238-0425

DESCRIPTION THREE GALLON SQUARE	
SCALE N.S.	PART NO. SPBM003-RT